



HORIZON
FITNESS

7.8 **A**
T R E A D M I L L

TREADMILL OWNER'S MANUAL
MANUEL DU PROPRIÉTAIRE DU TAPIS ROULANT
MANUAL DEL PROPIETARIO DE LA CAMINADORA



Read the TREADMILL GUIDE before using this OWNER'S MANUAL.

Lire le GUIDE D'UTILISATION DU TAPIS ROULANT avant de se référer au présent MANUEL DU PROPRIÉTAIRE.

Lea la GUÍA DE LA CAMINADORA antes de utilizar este MANUAL DEL PROPIETARIO.

IMPORTANT PRECAUTIONS



SAVE THESE INSTRUCTIONS

When using an electrical product, basic precautions should always be followed, including the following: Read all instructions before using this treadmill. It is the responsibility of the owner to ensure that all users of this treadmill are adequately informed of all warnings and precautions. If you have any questions after reading this guide, contact Customer Tech Support at the number listed on the back panel of the OWNER'S MANUAL.

This treadmill is intended for in-home use only. Do not use this treadmill in any commercial, rental, school or institutional setting. Failure to comply will void the warranty.



DANGER

TO REDUCE THE RISK OF ELECTRICAL SHOCK:

Always unplug the treadmill from the electrical outlet immediately after using, before cleaning, performing maintenance and putting on or taking off parts.



WARNING

TO REDUCE THE RISK OF BURNS, FIRE, ELECTRICAL SHOCK OR INJURY TO PERSONS:

- Never use the treadmill before securing the safety tether clip to your clothing.
- If you experience any kind of pain, including but not limited to chest pains, nausea, dizziness, or shortness of breath, stop exercising immediately and consult your physician before continuing.
- When exercising, always maintain a comfortable pace.
- Do not wear clothes that might catch on any part of the treadmill.
- Always wear athletic shoes while using this equipment.
- Do not jump on the treadmill.
- At no time should more than one person be on treadmill while in operation.
- This treadmill should not be used by persons weighing more than specified in the OWNER'S MANUAL WARRANTY SECTION. Failure to comply will void the warranty.
- When lowering the treadmill deck, wait until rear feet are firmly on the floor before stepping on the deck.
- Disconnect all power before servicing or moving the equipment. To clean, wipe surfaces down with soap and slightly damp cloth only; never use solvents. (See MAINTENANCE)
- The treadmill should never be left unattended when plugged in. Unplug from outlet when not in use, and before putting on or taking off parts.
- Do not operate under blanket or pillow. Excessive heating can occur and cause fire, electric shock, or injury to persons.
- Connect this exercise product to a properly grounded outlet only.

WARNING

TO REDUCE THE RISK OF BURNS, FIRE, ELECTRICAL SHOCK OR INJURY TO PERSONS:

- At NO time should pets or children under the age of 13 be closer to the treadmill than 10 feet.
- At NO time should children under the age of 13 use the treadmill.
- Children over the age of 13 or disabled persons should not use the treadmill without adult supervision.
- Use the treadmill only for its intended use as described in the treadmill guide and owner's manual.
- Do not use other attachments that are not recommended by the manufacturer. Attachments may cause injury.
- Never operate the treadmill if it has a damaged cord or plug, if it is not working properly, if it has been dropped or damaged, or immersed in water. Return the treadmill to a service center for examination and repair.
- Keep power cord away from heated surfaces. Do not carry this unit by its supply cord or use the cord as a handle.
- Never operate the treadmill with the air opening blocked. Keep the air opening clean, free of lint, hair, and the like.
- To prevent electrical shock, never drop or insert any object into any opening.
- Do not operate where aerosol (spray) products are being used or when oxygen is being administered.
- To disconnect, turn all controls to the off position, then remove plug from outlet.
- Do not use treadmill in any location that is not temperature controlled, such as but not limited to garages, porches, pool rooms, bathrooms, car ports or outdoors. Failure to comply will void the warranty.
- This treadmill is intended for in-home use only. Do not use this treadmill in any commercial, rental, school or institutional setting. Failure to comply will void the warranty.
- Do not remove the console covers unless instructed by Customer Tech Support. Service should only be done by an authorized service a technician.

It is essential that your treadmill is used only indoors, in a climate controlled room. If your treadmill has been exposed to colder temperatures or high moisture climates, it is strongly recommended that the treadmill is warmed up to room temperature before first time use. Failure to do so may cause premature electronic failure.





GROUNDING INSTRUCTIONS

This product must be grounded. If a treadmill should malfunction or breakdown, grounding provides a path of least resistance for electrical current to reduce the risk of electrical shock. This product is equipped with a cord having an equipment-grounding conductor and a grounding plug. The plug must be plugged into an appropriate outlet that is properly installed and grounded in accordance with local codes and ordinances.

DANGER

Improper connection of the equipment-grounding conductor can result in a risk of electric shock. Check with a qualified electrician or service provider if you are in doubt as to whether the product is properly grounded. Do not modify the plug provided with the product. If it will not fit the outlet, have a proper outlet installed by a qualified electrician.

This product is for use on a nominal 110-120 Volt circuit and has a grounding plug that looks like the plug in the illustration. Make sure that the product is connected to an outlet having the same configuration as the plug. No adapter should be used with this product.

This product must be used on a dedicated circuit. To determine if you are on a dedicated circuit, shut off the power to that circuit and observe if any other devices lose power. If so, move devices to a different circuit. Note: There are usually multiple outlets on one circuit. This treadmill should be used with a minimum 15-amp circuit.

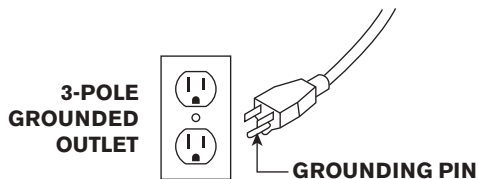

WARNING

Connect this exercise product to a properly grounded outlet only.

Never operate product with a damaged cord or plug even if it is working properly.

Never operate any product if it appears damaged, or has been immersed in water. Contact Customer Tech Support for replacement or repair.

ASSEMBLY



WARNING

There are several areas during the assembly process that special attention must be paid. It is very important to follow the assembly instructions correctly and to make sure all parts are firmly tightened. If the assembly instructions are not followed correctly, the treadmill could have parts that are not tightened and will seem loose and may cause irritating noises. To prevent damage to the treadmill, the assembly instructions must be reviewed and corrective actions should be taken.

Before proceeding, find your treadmill's serial number located on a white barcode sticker near the on/off power switch and power cord and enter it in the space provided below.

ENTER YOUR SERIAL NUMBER AND MODEL NAME IN THE BOXES BELOW:

» Refer to the SERIAL NUMBER and MODEL NAME when calling for service.

SERIAL NUMBER:

TM	
----	--

MODEL NAME: **HORIZON 7.8AT TREADMILL**

SERIAL NUMBER LOCATION

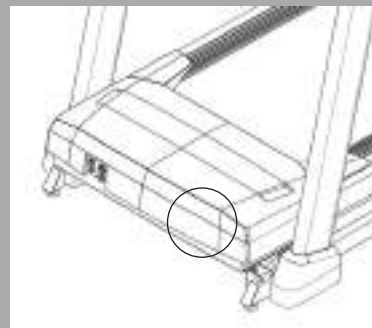



SPEAKERS _____ TABLET/READING RACK _____

WATER BOTTLE HOLDER _____

CONTROL PANEL AND DISPLAY WINDOWS _____

CONSOLE _____

CONSOLE FAN _____

PULSE RATE GRIPS _____

SAFETY KEY PLACEMENT _____

STORAGE TRAY _____

CROSS SUPPORT BAR _____

MOTOR COVER _____

CONSOLE MAST _____

ON/OFF SWITCH
POWER CORD _____

FOOT LATCH (UNDERNEATH DECK) _____

RUNNING BELT/RUNNING DECK _____

SIDE RAIL _____

CAUTION	ATTENTION	PRECAUCIÓN
KEEP HANDS AND FEET AWAY FROM THE AREA. HIGH-PRESSURE SHOCKS CAN CAUSE BODILY INJURY.	GARDER LES MAINS ET LES PIEDS LOIN DE CETTE REGION. LES AMORTISSEURS HAUTE PRESSION PEUVENT CAUSER DES BLESSURES CORPORELLES.	MANTENGA LAS MANOS Y LOS PIES LEJOS DE ESTA AREA. LOS AMORTIGUADORES DE ALTA PRESION PODRIAN CAUSAR LESIONES.

MAST COVERS _____

TRANSPORT WHEEL _____



FOOT LOCK LATCH DECAL
(UNDERNEATH FOOT LATCH)

ROLLER END CAP _____

REAR ROLLER
TENSION/ALIGNMENT BOLTS _____

TOOLS INCLUDED:

- 8 mm T-Wrench
- 6 mm L-Wrench
- 5 mm L-Wrench

PARTS INCLUDED:

- 1 Main Frame
- 1 Console Assembly
- 2 Console Masts
- 2 Mast Covers
- 2 Pulse Rate Grips
- 1 Cross Support Bar
- 1 Storage Tray
- 1 Hardware Kit
- 1 Safety Key
- 1 Audio Adapter Cable
- 1 Bottle of Silicone Lubricant
(for 2 applications)
- 1 Power Cord



NEED HELP?

If you have questions or if there are any missing parts, contact Customer Tech Support. Contact information is located on the back panel of this manual.

PRE ASSEMBLY

UNPACKING

Place the treadmill carton on a level flat surface. It is recommended that you place a protective covering on your floor. Take CAUTION when handling and transporting this unit. Never open box when it is on its side. Once the banding straps have been removed, do not lift or transport this unit unless it is fully assembled and in the upright folded position, with the lock latch secure. Unpack and assemble the unit where it will be used. The enclosed treadmill is equipped with high-pressure shocks and may spring open if mishandled. Never grab hold of any portion of the incline frame and attempt to lift or move the treadmill.



WARNING

DO NOT ATTEMPT TO LIFT THE TREADMILL! Do not move or lift treadmill from packaging until specified to do so in the assembly instructions. You may remove the plastic wrap from console masts.



WARNING

FAILURE TO FOLLOW THESE INSTRUCTIONS COULD RESULT IN INJURY!

NOTE: During each assembly step, ensure that ALL nuts and bolts are in place and partially threaded in before completely tightening any ONE bolt.

NOTE: A light application of grease may aid in the installation of hardware. Any grease, such as lithium bike grease is recommended.



ASSEMBLY STEP 1



HARDWARE FOR STEP 1			
PART	TYPE	DESCRIPTION	QTY
A	UPRIGHT GUIDE BOLT	M8X1.25PX11L	2
B	MAST BOLT	M8X1.25PX80L	8
C	FLAT WASHER	8.4X15.5X1.6T	8
D	SPRING WASHER	8.2X15.4X2.0T	8

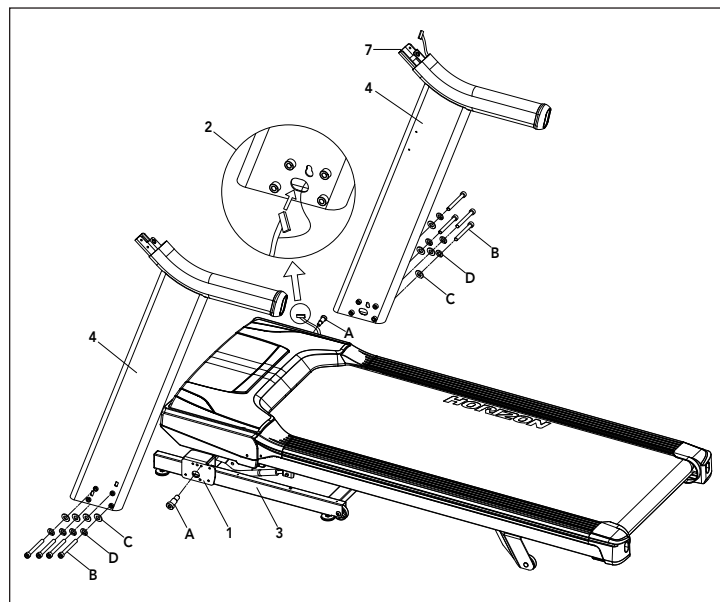

A Cut the yellow banding straps and lift the running deck upward from the rear to remove all contents from underneath the running deck.

B Open **HARDWARE FOR STEP 1**.

C Insert **UPRIGHT GUIDE BOLT (A)** into **MAIN FRAME BRACKET (1)** and fully tighten.

NOTE: Do not fully tighten the following bolts until the end of **STEP 4**.

D Attach **LEAD WIRE** to bottom end of **CONSOLE CABLE (2)**. Pull **LEAD WIRE** through **RIGHT CONSOLE MAST (4)**. After pulling the lead wire through the mast, the top of the **CONSOLE CABLE (2)** should be located at the **ATTACHMENT BRACKET (7)**.

E Attach **RIGHT CONSOLE MAST (4)** to **MAIN FRAME (3)** using **4 BOLTS (B)**, **4 FLAT WASHERS (C)** AND **4 SPRING WASHERS (D)**. Feed the extra console cable back into the upright mast.

NOTE: Be careful not to pinch the console cable while attaching the right console mast.

F Repeat **STEP E** on the **LEFT SIDE**.

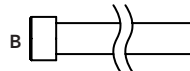
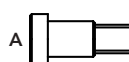

ASSEMBLY STEP 2

HARDWARE FOR STEP 2			
PART	TYPE	DESCRIPTION	QTY
F	ARC WASHER	8.2x18x1.5T	4
G	SHORT BOLT	M8x1.25Px15L	2
H	LONG BOLT	M8x1.25Px70L	2

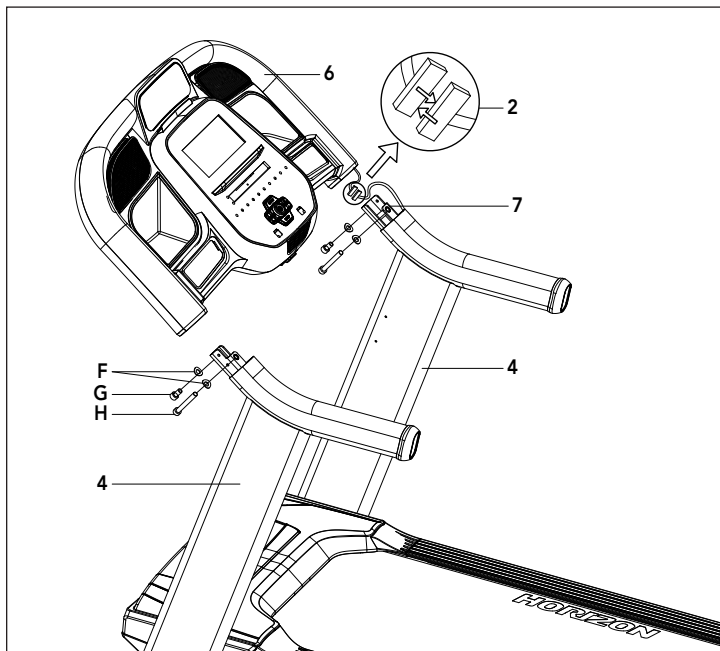

- A Open **HARDWARE FOR STEP 2**.
- B Have someone help hold the console while attaching the **CONSOLE CABLE (2)**. Use the lead wire to carefully pull the **CONSOLE CABLE (2)** out of the **RIGHT CONSOLE MAST (4)**. Attach the **CONSOLE CABLE (2)** from the **CONSOLE (6)** to the **CONSOLE CABLE (2)** from the top of the **RIGHT UPRIGHT MAST (4)**. Detach and discard the lead wire.
- C Carefully slide the **CONSOLE (6)** onto the **ATTACHMENT BRACKETS (7)** being careful not to pinch the **CONSOLE CABLE (2)**. Align the holes on the bottom side of the **CONSOLE (6)** with the holes on the **ATTACHMENT BRACKETS (7)**.
- D Attach the **CONSOLE (6)** to the **ATTACHMENT BRACKETS (7)** by first placing **ARC WASHERS (F)** onto **BOLTS (G) AND (H)** as illustrated. Insert **SHORT BOLTS (G)** into the top hole of the **ATTACHMENT BRACKET (7)** and **LONG BOLTS (H)** into the bottom hole.
- E Repeat **STEP D** for the opposite side.



ASSEMBLY STEP 3



HARDWARE FOR STEP 3			
PART	TYPE	DESCRIPTION	QTY
I	BOLT	M8X1.25X15L	8
J	SPRING WASHER	8.2X15.4X2.0T	8
K	FLAT WASHER	8.4X15.5X1.6T	8

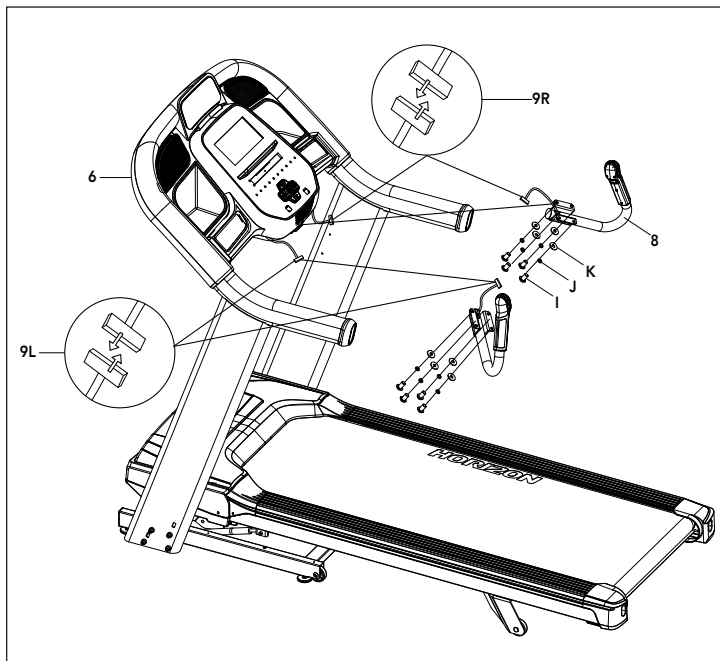

- A Open **HARDWARE FOR STEP 3**.
- B Attach **RIGHT SIDE PULSE RATE GRIP (8)** to the underside of the **CONSOLE (6)** using **4 BOLTS (I)**, **4 SPRING WASHERS (J)** and **4 FLAT WASHERS (K)**.
- C Connect the **RIGHT CONSOLE CABLES (9R)** and carefully tuck in wires to avoid damage.
- D Repeat **STEP B** on the **LEFT SIDE**.
- E Connect the **LEFT CONSOLE CABLES (9L)** and carefully tuck wires to avoid damage.

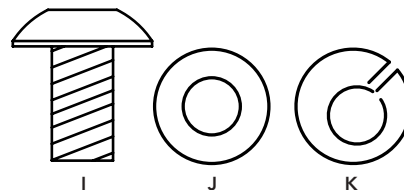

ASSEMBLY STEP 4



HARDWARE FOR STEP 4			
PART	TYPE	DESCRIPTION	QTY
E	BOLT	M6X1.0PX12L	6

- A Open **HARDWARE FOR STEP 4**.
- B Attach **CROSS SUPPORT BAR (5)** using holes on **UPRIGHT MASTS (4)** with **4 BOLTS (E)**.
- C Attach **STORAGE TRAY (10)** to the **CROSS SUPPORT BAR (5)** using holes on **CROSS SUPPORT BAR (5)** with remaining **2 BOLTS (E)**.

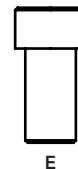
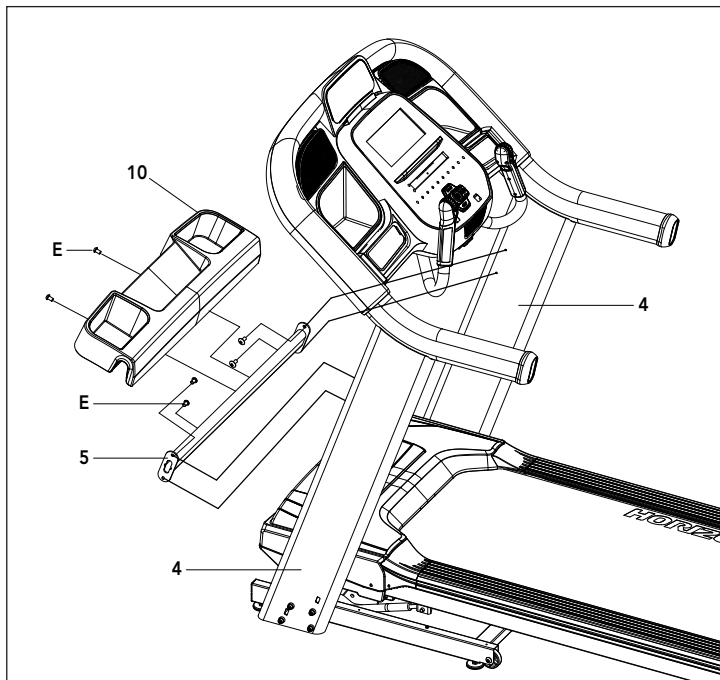

NOTE: Fully tighten all bolts from **PREVIOUS STEPS**

ASSEMBLY STEP 5



HARDWARE FOR STEP 5			
PART	TYPE	DESCRIPTION	QTY
L	SCREW	M4X1.0PX15L	2

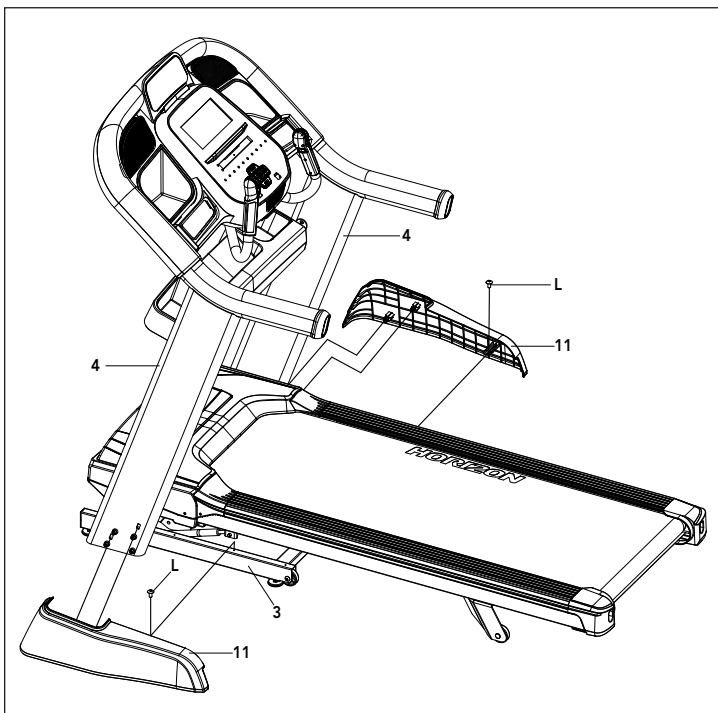

- A Open **HARDWARE FOR STEP 5**.
- B Slide **RIGHT SIDE MAST COVER (11)** onto the **RIGHT SIDE MAST (4)** by aligning tabs on **RIGHT SIDE MAST COVER (11)** with slots on **RIGHT SIDE MAST (4)**.
- C Attach **RIGHT SIDE MAST COVER (11)** to the **BASE FRAME (3)** using 1 **SCREW (L)**.
- D Repeat **STEPS B & C** on the **LEFT SIDE**.

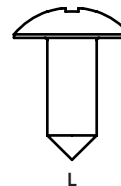

ASSEMBLY COMPLETE!

Before the first use, lubricate the treadmill deck by following the instructions in the **MAINTENANCE** section in the **TREADMILL GUIDE**.

TREADMILL OPERATION



This section explains how to use your treadmill's console and programming.

The **BASIC OPERATION** section in the **TREADMILL GUIDE** has instructions for the following:

- LOCATION OF THE TREADMILL
- USING THE SAFETY KEY
- FOLDING THE TREADMILL
- MOVING THE TREADMILL
- LEVELING THE TREADMILL
- TENSIONING THE RUNNING BELT
- CENTERING THE RUNNING BELT
- USING THE HEART RATE FUNCTION

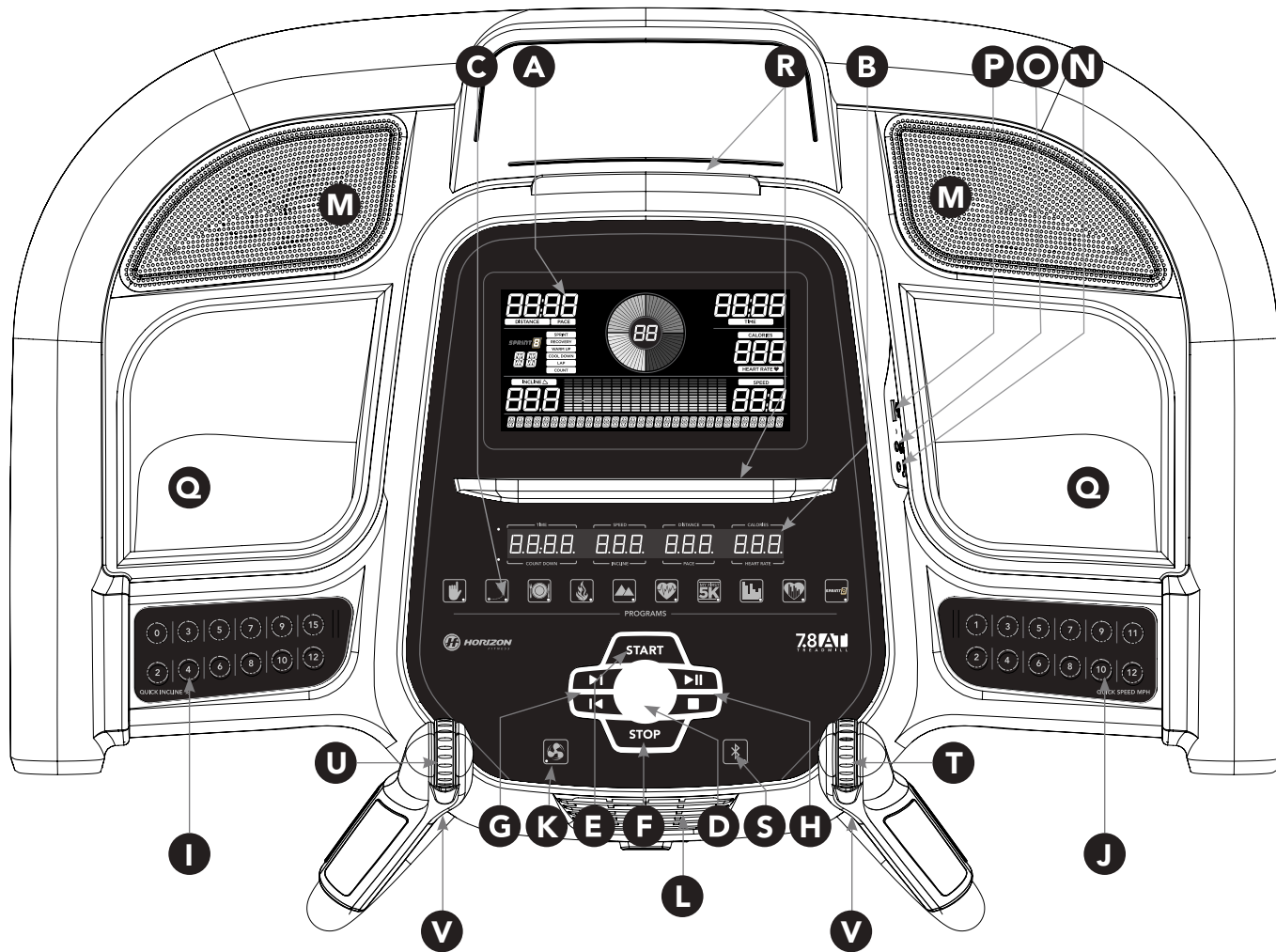

CONSOLE OPERATION

Note: There is a thin protective sheet of clear plastic on the overlay of the console that should be removed before use.

- A) **LCD DISPLAY WINDOW:** See detailed description on page 18.
- B) **LED DISPLAY:** Time/Count Down, Speed/Incline, Distance/Pace, Calories/Heart Rate.
- C) **WORKOUT LED INDICATORS:** indicates what workout is set for the current program.
- D) **SELECT TARGET/WORKOUT KNOB:** rotate/press to select your desired workout/target
- E) **START:** press to begin exercising, start your workout, or resume exercising after pause.
- F) **STOP:** press to pause/end your workout. Hold for 3 seconds to reset the console.
- G) **MEDIA SKIP KEYS:** used to skip to previous or next audio track.
- H) **MEDIA RUN/PAUSE/STOP KEYS:** top button used to pause/play media, bottom button stops media.
- I) **INCLINE QUICK KEYS:** used to reach desired incline more quickly.
- J) **SPEED QUICK KEYS:** used to reach desired speed more quickly.
- K) **FAN KEY:** press to turn fan on and off.
- L) **FAN:** personal workout fan.
- M) **SPEAKERS:** music plays through speakers when your CD / MP3 player is connected to the console.
- N) **AUDIO IN JACK:** plug your CD / MP3 player into the console using the included audio adaptor cable.
- O) **AUDIO OUT / HEADPHONE JACK:** plug your headphones into this jack to listen to your music through the headphones.
Note: when headphones are plugged into the headphone jack the sound will no longer come out through the speakers.
- P) **USB INPUT:** 1A/5V USB output power.
- Q) **WATER BOTTLE POCKETS:** holds personal workout equipment.
- R) **TABLET/READING RACKS:** holds tablet or reading material.
- S) **BLUETOOTH INDICATOR LIGHT:** displays when machine is paired with a Bluetooth compatible device.
- T) **SPEED SCROLL WHEEL:** used to adjust speed in small increments (.1 MPH).
- U) **INCLINE SCROLL WHEEL:** used to adjust incline in small increments (.5%).
- V) **INTERVAL KEYS:** these are programmable keys. When an user is selected, they can be programmed to a desired speed and incline setting.



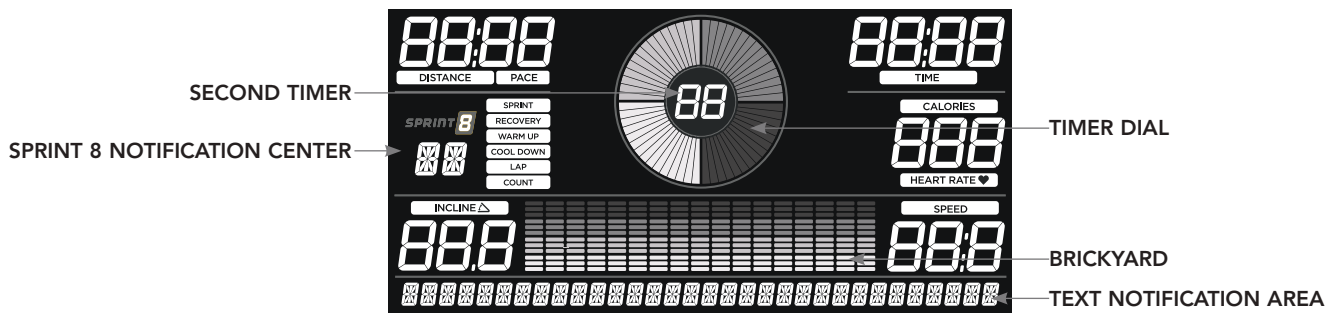

DISPLAY WINDOW

- **SECOND TIMER:** The timer counts up to 60 seconds in all programs except Sprint 8. In Sprint 8, the timer will count up or down depending upon the segment of the program you are in.
- **SPRINT 8 NOTIFICATION CENTER:** This area will light up during the Sprint 8 Program to keep you informed about what segment you are currently in, and how many sprints you have completed.
- **TIMER DIAL:** Each segment represents 1 second in all programs except Sprint 8. In Sprint 8, the length of the time for each segment varies depending upon the program segment you are in.
- **BRICKYARD:** This area shows the workout speed profile during setup and the current workout speed when a program is running.
- **TEXT NOTIFICATION AREA:** This area will show text prompts during setup and workouts.



GETTING STARTED

- 1) Check to make sure no objects are placed on the belt that will hinder the movement of the treadmill.
- 2) Plug in the power cord and turn the treadmill ON. (The ON/OFF switch is next to the power cord.)
- 3) Stand on the side rails of the treadmill.
- 4) Attach the safety key clip to part of your clothing making sure that it is secure and will not become detached during operation.
- 5) Insert the safety key into the safety keyhole in the console.
- 6) You have two options to start your workout:

A) QUICK START UP

Simply press the START key to begin working out.
Time, distance, and calories will all count up from zero. OR...

B) SELECT A WORKOUT OR TARGET

- 1) Select your **USER** by turning the workout knob and then pressing when your desired **USER** is displayed.
- 2) Select your **WEIGHT** by turning the workout knob and then pressing when your desired **WEIGHT** is displayed.
- 3) Select your **PROGRAM** by turning the workout knob and then pressing when your desired **PROGRAM** is displayed.
- 4) Adjust the **SETTING** by turning the workout knob and then pressing when your desired **SETTING** is displayed.
- 5) Press **START** to begin.



INCLINE SCROLL WHEEL

Roll forward/backward to increase/decrease incline.

SPEED SCROLL WHEEL

Roll forward/backward to increase/decrease speed

INTERVAL BUTTON 1

INTERVAL BUTTON 2

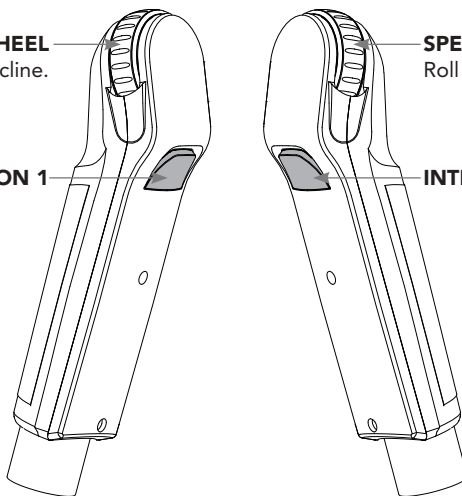

HOW TO PROGRAM AND USE CUSTOM INTERVAL BUTTONS

The programmable interval buttons located on the pulse rate grips are designed to help you customize this machine to match whatever workout you like to do the most.¹

The **LEFT and RIGHT INTERVAL BUTTONS** are programmable for speed and incline.

To program the **INTERVAL** button, **you must select a user**, start the machine, set the desired speed and incline, press and hold the desired **INTERVAL** button for three seconds until the treadmill beeps. Now the **INTERVAL** button is programmed to your settings. After programming the **INTERVAL** button, it will remember the setting for that user until reprogrammed.

Now when the **INTERVAL** button is pressed, the treadmill speed and incline will change to the settings you programmed for that button.

The most common type of workout these keys will help with is interval training. We suggest programming one of the **INTERVAL** buttons to your high intensity segments and the other to your recovery segments.

Another common use is to set one **INTERVAL** button to your warm up and cool down settings and the other to your desired workout settings.

These buttons should allow you to customize the settings of your treadmill to quickly fit the type of workout you enjoy most.

WORKOUT PROFILES



MANUAL: Control everything about your workout – from start to finish. This program is a basic workout with no pre-defined settings, allowing you to manually adjust the machine at any time. It begins with an incline at 0 and speed at 0.5 mph.



HILL CLIMB: Simulates a hill ascent and descent. This program helps tone muscle and improve cardiovascular ability. Incline changes and segments repeat every 30 seconds.

Incline changes and segments repeat every 30 seconds.

Segment	Warm Up		1	2	3	4	5	6	7	8	9	10
Time	4:00 Mins		30 sec	30 sec	30 sec	30 sec	30 sec	30 sec	30 sec	30 sec	30 sec	30 sec
Level 1	0	0	1	1.5	2	2.5	3	3	2.5	2	1.5	1
Level 2	0	0	1.5	2	2.5	3	3.5	3.5	3	2.5	2	1.5
Level 3	0	1	2	2.5	3	3.5	4	4	3.5	3	2.5	2
Level 4	0	1.5	2.5	3	3.5	4	4.5	4.5	4	3.5	3	2.5
Level 5	0	1.5	3	3.5	4	4.5	5	5	4.5	4	3.5	3
Level 6	0	1.5	3.5	4	4.5	5	5.5	5.5	5	4.5	4	3.5
Level 7	0	1.5	4	4.5	5	5.5	6	6	5.5	5	4.5	4
Level 8	0	2	4.5	5	5.5	6	6.5	6.5	6	5.5	5	4.5
Level 9	0	2	5	5.5	6	6.5	7	7	6.5	6	5.5	5
Level 10	0	2	5.5	6	6.5	7	7.5	7.5	7	6.5	6	5.5



MY FIRST 5K: This 9-week program is intended for inexperienced runners looking to run their first 5k or simply begin an exercise routine. It is designed specifically to keep you motivated and engaged, gradually building your strength, increasing your stamina and giving you the confidence it takes to complete your first 5k.



Week	Workout #1	Workout #2	Workout #3	Week	Workout #1	Workout #2	Workout #3		
1	5 minute warmup	5 minute warmup	5 minute warmup	4	5 minute warmup	5 minute warmup	5 minute warmup		
	1 min jog	1 min jog	1 min jog		3 minute jog	3 minute jog	3 minute jog		
	1.5 min walk	1.5 min walk	1.5 min walk		1.5 minute walk	1.5 minute walk	1.5 minute walk		
	1 min jog	1 min jog	1 min jog		5 minute jog	5 minute jog	5 minute jog		
	1.5 min walk	1.5 min walk	1.5 min walk		2.5 minute walk	2.5 minute walk	2.5 minute walk		
	1 min jog	1 min jog	1 min jog		3 minute jog	3 minute jog	3 minute jog		
	1.5 min walk	1.5 min walk	1.5 min walk		1.5 minute walk	1.5 minute walk	1.5 minute walk		
	1 min jog	1 min jog	1 min jog		5 minute jog	5 minute jog	5 minute jog		
	1.5 min walk	1.5 min walk	1.5 min walk		5 minute cooldown	5 minute cooldown	5 minute cooldown		
	1 min jog	1 min jog	1 min jog		5	5 minute warmup	5 minute warmup	5 minute warmup	
	1.5 min walk	1.5 min walk	1.5 min walk			5 minute jog	5 minute jog	5 minute jog	
	1 min jog	1 min jog	1 min jog			3 minute walk	3 minute walk	3 minute walk	
	1.5 min walk	1.5 min walk	1.5 min walk			5 minute jog	5 minute jog	5 minute jog	
	1 min jog	1 min jog	1 min jog			3 minute walk	3 minute walk	3 minute walk	
	1.5 min walk	1.5 min walk	1.5 min walk			5 minute jog	5 minute jog	5 minute jog	
1 min jog	1 min jog	1 min jog	5 minute cooldown	5 minute cooldown	5 minute cooldown				
1.5 min walk	1.5 min walk	1.5 min walk	6	5 minute warmup	5 minute warmup	5 minute warmup			
5 minute cooldown	5 minute cooldown	5 minute cooldown		5 minute jog	10 minute jog	25 minute jog			
2	5 minute warmup	5 minute warmup		5 minute warmup	3 minute walk	3 minute walk	5 minute cooldown		
	1.5 minute jog	1.5 minute jog		1.5 minute jog	8 minute jog	10 minute jog			
	2 minute walk	2 minute walk		2 minute walk	3 minute walk	5 minute cooldown			
	1.5 minute jog	1.5 minute jog		1.5 minute jog	5 minute jog				
	2 minute walk	2 minute walk	2 minute walk	5 minute cooldown					
	1.5 minute jog	1.5 minute jog	1.5 minute jog	7	5 minute warmup	5 minute warmup	5 minute warmup		
	2 minute walk	2 minute walk	2 minute walk		25 minute jog	25 minute jog	25 minute jog		
	1.5 minute jog	1.5 minute jog	1.5 minute jog		5 minute cooldown	5 minute cooldown	5 minute cooldown		
	2 minute walk	2 minute walk	2 minute walk		8	5 minute warmup	5 minute warmup	5 minute warmup	
	1.5 minute jog	1.5 minute jog	1.5 minute jog			28 minute jog	28 minute jog	28 minute jog	
	2 minute walk	2 minute walk	2 minute walk			5 minute cooldown	5 minute cooldown	5 minute cooldown	
	5 minute cooldown	5 minute cooldown	5 minute cooldown	9		5 minute warmup	5 minute warmup	5 minute warmup	
	3	5 minute warmup	5 minute warmup			5 minute warmup	30 minute jog	30 minute jog	30 minute jog
		1.5 minute jog	1.5 minute jog			1.5 minute jog	5 minute cooldown	5 minute cooldown	5 minute cooldown
		1.5 minute walk	1.5 minute walk		1.5 minute walk	Warmup and cooldown speeds 1.0 mph or 75% of walk speed, whichever is greater			
3 minute jog		3 minute jog	3 minute jog						
3 minute walk		3 minute walk	3 minute walk						
1.5 minute jog		1.5 minute jog	1.5 minute jog						
1.5 minute walk		1.5 minute walk	1.5 minute walk						
3 minute jog		3 minute jog	3 minute jog						
3 minute walk		3 minute walk	3 minute walk						
5 minute cooldown		5 minute cooldown	5 minute cooldown						



FAT BURN: Relatively slow and steady is the name of the game to maximize your weight-loss goals. Promotes weight loss by increasing and decreasing the speed and incline, while keeping you in your fat burning zone.



Speed and Incline changes, segments repeat every 30 seconds.

Segment		Warm Up		1	2	3	4	5	6	7	8
Time		4:00 Mins		30 sec	30 sec	30 sec	30 sec	30 sec	30 sec	30 sec	30 sec
Level 1	Incline	0	0.5	1.5	1.5	1	0.5	0.5	0.5	1	1.5
	Speed	0.5	1.5	2	2.5	3	3.5	4	3.5	3	2.5
Level 2	Incline	0	0.5	1.5	1.5	1	0.5	1	0.5	1	1.5
	Speed	0.5	1.9	2.5	3	3.5	4	4.5	4	3.5	3
Level 3	Incline	0.5	1	2	2	1.5	1	1	1	1.5	2
	Speed	0.5	2.3	3	3.5	4	4.5	5	4.5	4	3.5
Level 4	Incline	0.5	1	2	2	1.5	1	1	1	1.5	2
	Speed	1	2.6	3.5	4	4.5	5	5.5	5	4.5	4
Level 5	Incline	1	1.5	2.5	2.5	2	1.5	1.5	1.5	2	2.5
	Speed	1	3	4	4.5	5	5.5	6	5.5	5	4.5
Level 6	Incline	1	1.5	2.5	2.5	2	1.5	1.5	1.5	2	2.5
	Speed	1	3.4	4.5	5	5.5	6	6.5	6	5.5	5
Level 7	Incline	1.5	2	3	3	2.5	2	2	2	2.5	3
	Speed	1.4	3.8	5	5.5	6	6.5	7	6.5	6	5.5
Level 8	Incline	1.5	2	3	3	2.5	2	2	2	2.5	3
	Speed	1.4	4.1	5.5	6	6.5	7	7.5	7	6.5	6
Level 9	Incline	2	2.5	3.5	3.5	3	2.5	2.5	2.5	3	3.5
	Speed	1.4	4.5	6	6.5	7	7.5	8	7.5	7	6.5
Level 10	Incline	2	2.5	3.5	3.5	3	2.5	2.5	2.5	3	3.5
	Speed	1.4	4.9	6.5	7	7.5	8	8.5	8	7.5	7



CUSTOM: Allows you to create and reuse your perfect workout with a combination of a specific speed, incline and time or distance. The ultimate in personal programming. This is a time or distance based goal program.



TARGET PROFILES



DISTANCE: Push yourself and go further during your workout with 13 distance workouts. Choose from 1 mile, 2 miles, 5k, 5 miles, 10k, 8 miles, 15k, 10 miles, 20k, half marathon, 15 miles, 20 miles, and marathon goals. You set your level.

Incline changes and all segments are 0.1 miles.

Segment	Warm Up		1	2	3	4	5	6	7	8	9	10	11	12	13	14	15
Distance	.1 mi	.1 mi	.1 mi	.1 mi	.1 mi	.1 mi	.1 mi	0.1 mi	.1 mi	.1 mi	.1 mi	.1 mi	.1 mi	.1 mi	.1 mi	.1 mi	.1 mi
Level 1	0	0	0	0	0	0	0	0	0	0	0	0	0	0	0	0	0
Level 2	0	.5	1	3	2	3	2	3	2.5	3.5	2.5	3	2	3	2	3	1
Level 3	.5	1	1.5	3.5	1.5	3.5	2.5	3.5	2.5	4	2.5	3.5	2.5	3.5	1.5	3.5	1.5
Level 4	.5	1	1.5	3.5	2.5	3.5	2.5	3.5	3	4	3	3.5	2.5	3.5	2.5	3.5	1.5
Level 5	1	1.5	2	4	2	4	3	4	3	4.5	3	4	3	4	2	4	2
Level 6	1	1.5	2	4	3	4	3	4	3.5	4.5	3.5	4	3	4	3	4	2
Level 7	1.5	2	2.5	4.5	2.5	4.5	3.5	4.5	3.5	5	3.5	4.5	3.5	4.5	2.5	4.5	2.5
Level 8	1.5	2	2.5	4.5	3.5	4.5	3.5	4.5	4	5	4	4.5	3.5	4.5	3.5	4.5	2.5
Level 9	2	2.5	3	5	3	5	4	5	4	5.5	4	5	4	5	3	5	3
Level 10	2	2.5	3	5	4	5	4	5	4.5	5.5	4.5	5	4	5	4	5	3



CALORIES: Set goals for burning calories from 20 to 980 calories in 20 calorie increments. You set your level to keep you in your fat burning zone.

Incline changes and all segments are 20 calories.

Segment	Warm Up		1	2	3	4	5	6	7	8	9	10	11	12	13	14	15
Calories	20 cal	20 cal	20 cal	20 cal	20 cal	20 cal	20 cal	20 cal	20 cal	20 cal	20 cal	20 cal	20 cal	20 cal	20 cal	20 cal	20 cal
Level 1	0	0	0	0	0	0	0	0	0	0	0	0	0	0	0	0	0
Level 2	0	0.5	1	3	2	3	2	3	2.5	3.5	2.5	3	2	3	2	3	1
Level 3	0.5	1	1.5	3.5	1.5	3.5	2.5	3.5	2.5	4	2.5	3.5	2.5	3.5	1.5	3.5	1.5
Level 4	0.5	1	1.5	3.5	2.5	3.5	2.5	3.5	3	4	3	3.5	2.5	3.5	2.5	3.5	1.5
Level 5	1	1.5	2	4	2	4	3	4	3	4.5	3	4	3	4	2	4	2
Level 6	1	1.5	2	4	3	4	3	4	3.5	4.5	3.5	4	3	4	3	4	2
Level 7	1.5	2	2.5	4.5	2.5	4.5	3.5	4.5	3.5	5	3.5	4.5	3.5	4.5	2.5	4.5	2.5
Level 8	1.5	2	2.5	4.5	3.5	4.5	3.5	4.5	4	5	4	4.5	3.5	4.5	3.5	4.5	2.5
Level 9	2	2.5	3	5	3	5	4	5	4	5.5	4	5	4	5	3	5	3
Level 10	2	2.5	3	5	4	5	4	5	4.5	5.5	4.5	5	4	5	4	5	3



TARGET HEART RATE: This program is designed for you to improve your overall cardiovascular fitness levels. You simply set your target heart rate. The program will then monitor and adjust the intensity level to maintain your heart rate within your targeted range while you exercise – a proven method to maximize your weight loss and fitness goals. A chest strap is required and must be worn during the duration of this program. See below for calculating your target heart rate.



Calculating Your Target Heart Rate

The first step in knowing the right intensity for your training is to find out your maximum heart rate (max HR = 220 – your age). The age-based method provides an average statistical prediction of your max HR and is a good method for the majority of people, especially those new to heart rate training.

The most precise and accurate way of determining your individual max HR is to have it clinically tested by a cardiologist or exercise physiologist through the use of a maximal stress test. If you are over the age of 40, overweight, have been sedentary for several years, or have a history of heart disease in your family, clinical testing is recommended.

This chart gives examples of the heart rate range for a 30 year old exercising at 5 different heart rate zones. For example, a 30-year-old's max HR is $220 - 30 = 190$ bpm and 90% max HR is $190 \times 0.9 = 171$ bpm.

Additional target heart rate notes:

The treadmill incline will automatically adjust to bring you near your specified heart rate.

If there is no heart rate detected, the unit will not change the incline.

If your heart rate is 25 beats over your target zone the program will shut down.

Target Heart Rate Zone	Workout Duration	Example THR (age 30)	Your THR	Recommend For
VERY HARD 90 - 100%	< 5 min	171-190 BPM		Fit persons for athletic training
HARD 80 - 90%	2-10 min	152-171 BPM		Shorter Workouts
MODERATE 70 - 80%	10-40 min	133-152 BPM		Moderately long Workouts
LIGHT 60 - 70%	40-80 min	114-133 BPM		Longer and frequently repeated shorter exercises
VERY LIGHT 50 - 60%	20-40 min	104-114BPM		Weight management and active recovery



TO RESET THE CONSOLE

Hold STOP key for 3 seconds.

FINISHING YOUR WORKOUT

When your workout is complete, the unit will beep. Your workout information will stay displayed on the console for 30 seconds and then reset.

USING YOUR MUSIC DEVICE

The 7.8AT Treadmill will connect and stream music from your compatible music device. This includes many smart phones and traditional mp3 players such as the iPod®.

Your 7.8AT Treadmill comes equipped with Bluetooth speakers. Bluetooth compatible devices (running Bluetooth 4.0) can stream music wirelessly from your device to the speakers. You can also connect your music device via an audio cable and still stream music through the speakers. Instructions for both types of audio connection are detailed below.

CONNECTING VIA BLUETOOTH 4.0LE

- 1) Check to ensure that your music device is Bluetooth 4.0 compatible
- 2) Go into your device's Bluetooth settings and scan for devices.
- 3) On your music device, locate the Bluetooth device list. Select your unit that appears on this list.
Wait for your music device to finish pairing with the unit.
- 4) You will know when pairing is successful when your music device shows the unit as now being a paired device.

WHEN UNIT IS POWERED OFF THEN BACK ON

If you turn your unit off, or if it goes into sleep mode, the next time it is powered on the unit will look to pair with the last music device with which it was paired. It will automatically pair at this time.

RE-PAIRING MUSIC DEVICES

In the event that the unit cannot find the last paired music device (for example, the music device is off or not being used) then the unit will stop looking to pair with the music device. If this happens, and if you wish to use your music device again, then you will need to go through the pairing process listed above and re-pair through your music device's settings.

USING MULTIPLE MUSIC DEVICES

If multiple devices are being paired with the unit (i.e.: multiple users are using the unit and pairing their music devices with it) then the unit will look to pair with the last device used and "forget" other devices. If you wish to re-pair a "forgotten" music device, then you will need to un-pair the current paired device and then re-pair your device through the pairing procedure noted above.



CONNECTING VIA AN AUDIO CABLE

- 1) Connect the included AUDIO ADAPTOR CABLE to the AUDIO IN JACK on the top right of the console and the headphone jack on your music device.
- 2) Use your CD / MP3 player buttons to adjust song settings.
- 3) Remove the AUDIO ADAPTOR CABLE when not in use.
- 4) If you don't want to use the SPEAKERS, you can plug your headphones into the AUDIO OUT JACK at the bottom of the console. This ensures that if you accidentally catch the headphone line while running, you won't drop your device to the ground.

AFG TABLET CONNECTED FITNESS SYSTEM

Your Horizon machine is tablet ready, allowing you to use Bluetooth 4.0 technology to wirelessly connect your tablet to your Horizon machine. Using the free downloadable AFG PRO FITNESS app will enable you to control your unit's operating functions via your tablet. The app will also allow you to monitor your workout, track your progress and view your workout history. The AFG PRO FITNESS app can be downloaded from either the iTunes store for iOS devices or from the Google store for Android devices.

For information about connecting your tablet to your Horizon machine setting up the AFG PRO FITNESS and controlling and monitoring your workout with your tablet, see the AFG Connected Fitness Manual included with your unit.

BLUETOOTH HEART RATE MONITORING

The 7.8AT Treadmill is equipped with multi-channel Bluetooth which enables you to wirelessly connect compatible Bluetooth heart rate monitoring devices to this unit. You will need to ensure that your wireless heart rate monitoring device is Bluetooth 4.0 compatible and is also "open" to sharing data. Non-"open" or "closed" devices typically only share data with their proprietary apps. The 7.8AT Treadmill needs an "open" device to receive data from the device. You may need to consult with your device's owner's manual or the manufacturer to confirm if it is an open device.

If you are using a tablet and running the AFG PRO FITNESS app, the compatible Bluetooth heart rate monitoring device will pair automatically to the app. The machine's console will then receive the heart rate information from your tablet. If you wish to use the Bluetooth heart rate monitoring device without a tablet and AFG PRO FITNESS app, press and hold the Bluetooth button on the console for 5 seconds. This will enable the console to communicate directly with the Bluetooth heart rate monitoring device. Heart rate information will be displayed on your console display. When in heart rate monitor mode, the console will be unable to communicate to the tablet. To enable tablet communication, press and hold the Bluetooth button on the console for 5 seconds or reset power.

LIMITED HOME-USE WARRANTY



WEIGHT CAPACITY = 375 lbs (170kilograms)



FRAME • LIFETIME

Horizon Fitness warrants the frame against defects in workmanship and materials for the lifetime of the original owner, so long as the device remains in the possession of the original owner. (The frame is defined as the welded metal base of the unit and does not include any parts that can be removed.)

MOTOR • LIFETIME

Horizon Fitness warrants the motor against defects in workmanship and materials for the lifetime of the original owner, so long as the device remains in the possession of the original owner. Labor or installation of motor is not covered under the motor warranty.

ELECTRONICS & PARTS • 5 YEAR

Horizon Fitness warrants the electronic components, finish and all original parts for a period of five years from the date of original purchase, so long as the device remains in the possession of the original owner.

LABOR • 2 YEAR

Horizon Fitness shall cover the labor cost for the repair of the device for a period of two years from the date of the original purchase, so long as the device remains in the possession of the original owner.

EXCLUSIONS AND LIMITATIONS

Who IS covered:

- The original owner and is not transferable.

What IS covered:

- Repair or replacement of a defective motor, electronic component, or defective part and is the sole remedy of the warranty.

What IS NOT covered:

- Normal wear and tear, improper assembly or maintenance, or installation of parts or accessories not originally intended or compatible with the equipment as sold.
- Damage or failure due to accident, abuse, corrosion, discoloration of paint or plastic, neglect, theft, vandalism, fire, flood, wind, lightning, freezing, or other natural disasters of any kind, power reduction, fluctuation or failure from whatever cause, unusual atmospheric conditions, collision, introduction of foreign objects into the covered unit, or modifications that are unauthorized or not recommended by Horizon Fitness.
- Incidental or consequential damages. Horizon Fitness is not responsible or liable for indirect, special or consequential damages, economic loss, loss of property, or profits, loss of enjoyment or use, or other consequential damages of whatsoever nature in connection with the purchase, use, repair or maintenance of the equipment. Horizon Fitness does not provide monetary or other compensation for any such repairs or replacement parts costs, including but not limited

to gym membership fees, work time lost, diagnostic visits, maintenance visits or transportation.

- Equipment used for commercial purposes or any use other than a single family or Household, unless endorsed by Horizon Fitness for coverage.
- Equipment owned or operated outside the US and Canada.
- Delivery, assembly, installation, setup for original or replacement units or labor or other costs associated with removal or replacement of the covered unit.
- Any attempt to repair this equipment creates a risk of injury. Horizon Fitness is not responsible or liable for any damage, loss or liability arising from any personal injury incurred during the course of, or as a result of any repair or attempted repair of your fitness equipment by other than an authorized service technician. All repairs attempted by you on your fitness equipment are undertaken AT YOUR OWN RISK and Horizon Fitness shall have no liability for any injury to the person or property arising from such repairs.
- If you are out of the manufacturer's warranty but have an extended warranty, refer to your extended warranty contract for contact information regarding requests for extended warranty service or repair.

SERVICE/RETURNS

- In-home service is available within 150 miles of the nearest authorized Service Provider (Mileage beyond 150 miles from an authorized service center is the responsibility of the consumer).
- All returns must be pre-authorized by Horizon Fitness.
- Horizon Fitness' obligation under this warranty is limited to replacing or repairing, at Horizon Fitness' option, the same or comparable model.
- Horizon Fitness may request defective components be returned to Horizon Fitness upon completion of warranty service using a prepaid return shipping label. If you have been advised to return parts and did not receive a label, please contact Customer Tech Support.
- Replacement units, parts and electronic components reconditioned to as-new condition by Horizon Fitness or its vendors may sometimes be supplied as warranty replacement and constitute fulfillment of warranty terms.
- This warranty gives you specific legal rights, and your rights may vary from state to state.





CUSTOMER TECH SUPPORT

DO NOT RETURN TO THE RETAILER

if you have any problems during assembly or if parts are missing.

For fast and friendly service, please contact one of our trained customer technicians via phone, email or our website.

We want to know if you have a problem and we want to have an opportunity to correct it for you.

NOTE: Please read the TROUBLESHOOTING section in the TREADMILL GUIDE before contacting Customer Tech Support. Additional product information is available on our website.



ASSISTANCE TECHNIQUE

NE PAS RETOURNER L'APPAREIL AU DÉTAILLANT

en cas de difficulté lors de l'assemblage ou si des pièces manquent.

Pour obtenir un service rapide et utile, veuillez communiquer avec un de nos techniciens formés au soutien à la clientèle par téléphone, courriel ou notre site Web.

Si vous avez un problème, n'hésitez pas à nous contacter afin que nous puissions vous aider à le résoudre.

REMARQUE : lire la section DÉPANNAGE du GUIDE D'UTILISATION DU TAPIS ROULANT avant de communiquer avec l'assistance technique. Des renseignements supplémentaires sur le produit sont disponibles sur notre site Web.



SERVICIO DE ASISTENCIA TÉCNICA PARA CLIENTES

NO DEVOLVER AL VENDEDOR

si tiene algún inconveniente durante el armado o si faltan piezas.

Para obtener un servicio rápido y grato, comuníquese con uno de nuestros técnicos capacitados para la atención de clientes vía teléfono, correo electrónico o nuestro sitio web.

Queremos saber si tiene un problema y queremos tener la oportunidad de corregirlo para usted.

NOTA: Antes de comunicarse con el Servicio de asistencia técnica para clientes, lea la sección de RESOLUCIÓN DE PROBLEMAS en la GUÍA DE LA CAMINADORA. En nuestro sitio web hay información adicional sobre el producto.



USA & CANADA:

1-855-396-2524

techsupport@horizonfitness.com

www.horizonfitness.com

Horizon Fitness

1600 Landmark Drive,

Cottage Grove WI, 53527