

# sitNcycle

[www.sitncycle.com](http://www.sitncycle.com)



Thank you for choosing the sitNcycle. We take great pride in producing this quality product and hope it will provide many hours of quality exercise to make you feel better, look better and enjoy life to its fullest.

The sitNcycle is not a typical exercise bike; it is designed to be a low resistance long duration exercise product. This is great for the office or the home and for use during activities where an individual would sit for long periods of time.

**CAUTION: WEIGHT ON THIS PRODUCT SHOULD NOT EXCEED 136KG / 300LBS**

The Product May Vary Slightly From the  
Picture Shown Above  
**MADE IN CHINA**

# SAFETY INSTRUCTIONS

**WARNING: To reduce the risk of serious injury, read the following safety instructions before using the item.**

1. Read all warnings posted on the equipment. Follow all safety instructions in this manual.
2. Read this Owner's Manual and follow it carefully before using the equipment. Make sure that it is properly assembled and all fasteners are tightened before use.
3. Do not allow children and pets to use or play on the equipment. Always keep children and pets away from the equipment when it is in use.
4. This equipment must be placed on a level and stable hard flooring or carpet. Do not position the equipment on loose rugs or uneven surfaces.
5. Inspect the equipment for worn or loose components prior to each use.
6. Tighten / replace any loose or worn components prior to using the equipment.
7. Always choose the workout which best fits your physical, strength and flexibility level. Know your limits and train within them. Always use common sense when exercising.
8. Do not wear loose or dangling clothing while using the equipment.
9. Never exercise in bare feet or socks; always wear correct footwear, such as running, walking, or cross-training shoes.
10. Be careful to maintain your balance while getting on this product, using this product and getting off this product; loss of balance may result in a fall and/ or serious bodily injury.
11. The equipment must not be used by persons weighing over 300 pounds /136 kilograms.
12. The equipment should be used by only one person at a time.
13. The equipment is for home usage only.
14. Maintenance: Replace the defective components immediately and / or discontinue the use of the equipment until it is repaired.
15. Make sure that adequate space is available for access to and passage around the equipment; keep at least a distance of 1 meter from any obstruction object while using the machine.
16. If you feel faint or dizzy, discontinue use of this equipment immediately. Serious bodily injury can occur if this equipment is not assembled and used correctly. Serious bodily injury can also occur if all instructions are not followed.
17. Follow your Doctor's recommendations in developing your own personal fitness program. You must NOT use the sitNcycle without your doctor's consent if you:
  - a. Are pregnant
  - b. Have had a recent operation or surgery
  - c. Have knee, shoulder, back or neck injuries
  - d. Have a Heart condition or cardiovascular disease• High blood pressure• Acute thrombosis• Acute hernia
  - e. Have Severe diabetes • Epilepsy• Severe migraines• Malignant tumour
  - f. Have a Pacemaker, implants, artificial joint(s) or limb(s), stents or IUD• Any recent illnesses or infections
  - g. Have Cancer

**WARNING:** Before starting any exercise or conditioning program you should consult with your personal Doctor to see if you require a complete physical exam. This is especially important if you are over the age of 35, have never exercised before, are pregnant, or suffer from any illness

 **READ AND FOLLOW THE SAFETY PRECAUTIONS. FAILURE TO FOLLOW THESE INSTRUCTIONS CAN RESULT IN SERIOUS BODILY INJURY**

# ASSEMBLY PARTS

Unpack the box in a clear area. Follow the **List of Assembly Parts** below to check and make sure all of the assembly parts are present and in good condition. Do not dispose of the packing material until the trial period has expired. The tools needed for assembly have been included. If anything is missing please check the packing materials to verify it was not concealed in this material.

ASSEMBLY PARTS	Part No.	Q'TY
SEAT CUSHION WITH HANDLE	#1	1 piece
SEAT POST	#2	1 piece
PEDALS (RIGHT and LEFT) with 2 preinstalled spring washers	#29 LEFT and #30 RIGHT	2 pcs (1 of each) & 2 spring washers
MAIN FRAME	#4	1 piece
BASE ASSEMBLY	#12	1 piece
HARDWARE KIT	see details on page 4	



# HARDWARE IDENTIFICATION CHART



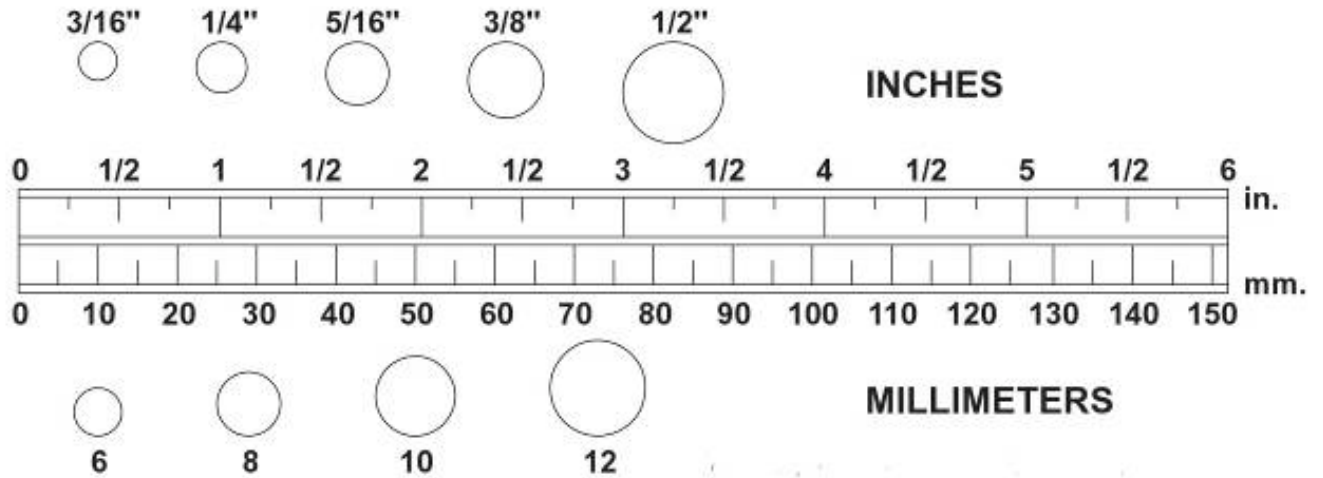

Unpack the box in a clear area. Review the **Hardware Kit List** below. This chart is provided to help identify the hardware used in the assembly process. Place the washers, the ends of the bolts, or screws on the circles to check for the correct diameter. Use the small ruler to check the length of the bolts and screws. Do not dispose of the packing material until the trial period has expired

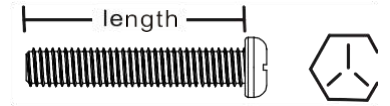

**NOTICE:** The length of all bolts and screws, except those with flat heads, are measured from below the head to the end of the bolt or screw. Flat head bolts and screws are measured from the top of the head to the end of the bolt or screw

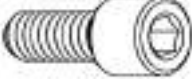

**Note:** Please review the contents of the hardware kit pictured below. Some small parts may have been pre-attached for shipping. If a part is not in the hardware bag, check to see if it has been pre-assembled. You can refer to the exploded diagram on page 13 for hardware placement

HARDWARE KIT	Part No. and Description	Q'TY
	#15 Foot Pads	4 pcs
	#16 Bolt (M10x13mm)	4 pcs
	#33 Pan Head Screw(18mm)	2pcs
	#3 Bolt (M5x15mm)	3 pcs
	#37 Spring Washer (Φ10mm)	4 pcs
	#38 Flat Washer (Φ10mm)	4 pcs

**THE FOLLOWING TOOLS ARE INCLUDED FOR ASSEMBLY:**



Wrench



ALLEN WRENCH (8 mm)



ALLEN WRENCH (6 mm)



PHILLIPS HEAD SCREWDRIVER

# ASSEMBLY INSTRUCTIONS

## STEP1-Base Support Frame Assembly



FIG 1-A





Fig 1-B



Fig 1-C



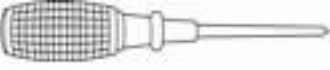

Fig 1-D

	#16 x 4
	#37 x 4
	#38 x 4



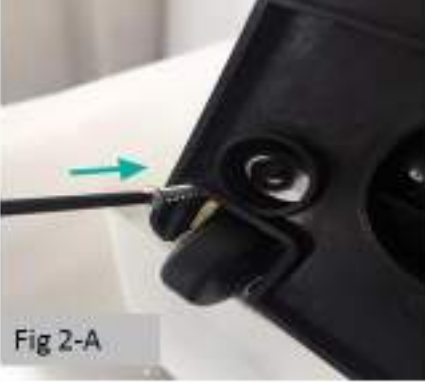
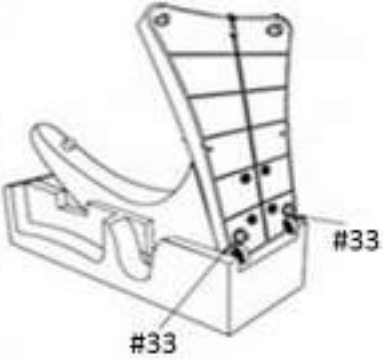

1. Unpack the sitNcycle from the shipping carton and remove the packing materials.
2. Place the upper Styrofoam packaging upside down on the floor. Then remove the sitNcycle main frame and place it on to the Styrofoam as pictured on the left in Fig 1-A.
3. Attach the base assembly #13 to the main frame #8. To ensure proper assemble, slide the base assembly into the main frame. Ensure the bolt holes line up properly.
4. Thread the 4x#37 Spring Washer ( $\Phi 10$ ) and 4x#38 Flat Washers ( $\Phi 10$ ) onto the 4x#16 bolts (M10\*13mm) as pictured in Fig 1-C.
5. Secure the base assembly to the main frame using bolt/washers from step 4. Follow the bolting pattern in Fig 1-D, loosely screw in the bolts following the pattern 1-4. When all 4 bolts have been inserted fully tighten bolts using the same pattern.

# ASSEMBLY INSTRUCTIONS

## STEP2–Secure the Base Assembly Bottom Cover

		 #33 x 2
 Fig 2-A	 #33 #33	<p>After the base frame has been attached and the bolts are completely tightened.</p> <ol style="list-style-type: none"><li>1. Secure the base frame cover bottom to the base frame using 2 x #33 pan head screws (18mm) as pictured in Fig 2-A.</li></ol>

## STEP3– Foot Pads

		 #15 x 4
 Fig 3-A	 #15 #15 #15 #15	<ol style="list-style-type: none"><li>1. Once the base frame bottom cover is attached, screw the 4 foot pads (#15) in to the base frame as pictured on the left as pictured in Fig 3-A</li><li>2. Verify that all of the bolts and fasteners are completely tightened from the previous steps, before moving forward.</li></ol>
		<p><b>Note: For the next steps, stand the bike upright on the foot pads.</b></p>

# ASSEMBLY INSTRUCTIONS

## STEP4-Pedals

**NOTE: THE PEDALS ARE STAMPED, L AND R ON THE PEDAL THREADED SHAFT.**

The left and right pedals are not interchangeable. You must only assemble the right pedal to the right side crank arm and the left pedal to the left side crank arm. The left and right side are determined from the seated position. Failure to follow the above instructions may cause damage. **Ensure the spring washer is in place on the pedal shaft before attaching the pedal.**



This part may be preinstalled at the factory.

### LEFT SIDE

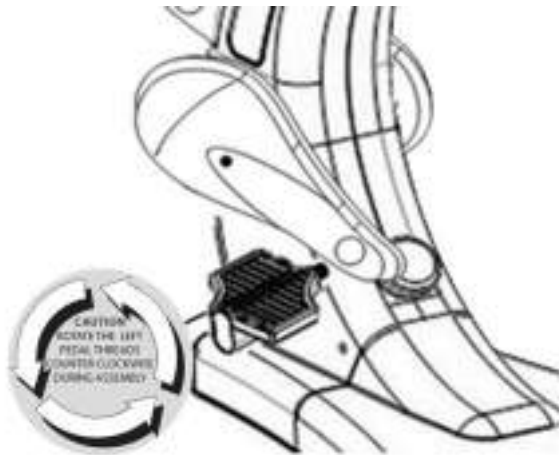

### RIGHT SIDE



1. Ensure the Spring Washer is on the pedal shaft. Using your hands, thread the **Left Pedal** **COUNTER-CLOCKWISE** onto the **LEFT** crank arm. After the pedal is hand tightened use the supplied wrench to completely tighten the pedal.



2. Ensure the Spring Washer is on the pedal shaft. Using your hands, thread the **Right Pedal** **CLOCKWISE** onto the **RIGHT** crank arm. After the pedal is hand tightened use the supplied wrench to completely tighten the pedal.

# ASSEMBLY INSTRUCTIONS

## STEP5–Seat Assembly



#3 x 3

1. For ease of assembly, turn the seat upside down and place it on the floor or any flat surface.
2. Line up the holes in the seat post with the threaded holes on the seat as pictured in Fig 5-A.
3. Secure the seat post to the seat using 3 x #3 bolts (M5x15mm) as pictured in Fig 5-B.
4. Tighten all bolts now.

The transportation handle has been preinstalled.

## STEP6–Seat Installation

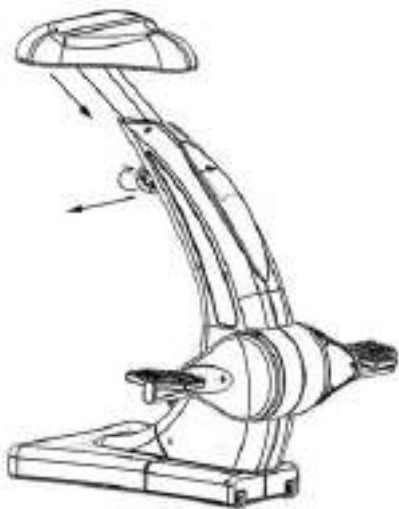

**NOTE: Do not completely remove the adjustment knob from the frame. To adjust the seat you will need to loosen the knob and then pull the knob outward.**

1. To insert the seat, turn the adjustment knob counter clockwise to loosen.
2. Pull the knob outward and insert the seat at the same time, until the seat post is fully inserted and the seat rests on the plastic cover.
3. Release the knob and slowly pull up on the seat until it locks in place.
4. After releasing the pin and the seat is locked in place, verify that the seat will not move up or down.
5. Tighten the knob by turning it clockwise until it is completely tight.



## SEAT ADJUSTMENT

**Warning: Do not use the sitNcycle without verifying that the seat is locked in place. Before moving or using the bike, pull upward on the seat to verify it cannot be removed.**

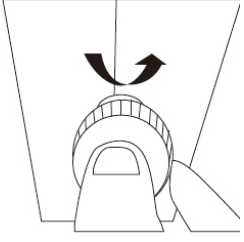
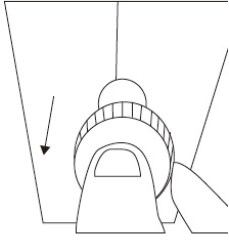
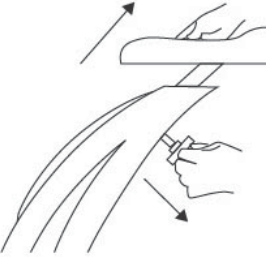
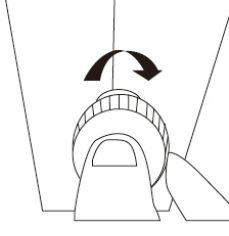
	<p>1. Turn the seat adjustment knob counter-clockwise to loosen.</p>		<p>2. Pull back the seat adjustment knob to release the seat.</p>
	<p>3. While holding the knob out, move the seat up or down. The seat will move in a 45 degree motion. Once the required height is reached, release the knob and slowly push the seat downward until the pin snaps in place. Verify that the seat is locked in place by pulling upward on the seat. If the seat is properly locked, the seat will not move up or down.</p>		<p>4. Turn the seat adjustment knob clockwise to tighten the adjuster knob. Completely tighten the knob prior to use.</p>

Materials: The seat cushion is made of 100% polyurethane

# Battery Installation



**NOTE: The computer monitor will not function without 1 AAA (1.5 volt) battery. (Battery may not be included.)**

1. Open the display door panel by gently pressing down on the tab in the front panel and pull open the display door downward. See Fig BI-1.
2. Remove the monitor from the door panel by gently pushing the monitor along the tracks to the left side. See Fig BI-2.
3. Turn over the monitor to expose the battery compartment. Insert the battery in the direction shown in Fig BI-3.
4. Turn the monitor back over and gently slide the monitor back on along the tracks on the door panel. See Fig BI-4. Ensure that the monitor is locked in place. Ensure the computer wires from the cycle frame and monitor are connected.

**NOTE: Batteries should be recycled or disposed of in accordance with state and local guidelines.**

For best results, use type alkaline batteries.

Install only new batteries of the same type in your product.

Failure to insert batteries in the correct polarity, as indicated in the battery compartment, may shorten the life of the batteries or cause batteries to leak.

Do not mix old and new batteries.

Do not mix Alkaline, Standard (Carbon-Zinc) or Rechargeable (Nickel Cadmium) or (Nickel Metal Hydride) batteries.

Danger of explosion if battery is incorrectly replaced.

# Monitor Display

**NOTE:** The monitor will not function without 1 AAA battery (see Installation instructions on page 10)

For proper function please ensure the monitor is properly locked in place and the computer wires from the cycle frame and the monitor are properly connected.



<p><b>DISPLAY BUTTOM</b></p>	<p>The display will be blank when not in use. To use simply start pedaling and the monitor will display your <b>SPEED</b> (top number) and one of the display functions (lower number).</p> <p>The display will automatically start in <b>SCAN</b> mode. During this mode the <b>SCAN</b> icon on the left side of the display will be visible and flashing. This mode will cycle you through each of the display functions as you work out. To leave scan mode press the display button (located below the display screen) and release. This will select the next display function. This function will remain on the display throughout your workout. Press the display button again to toggle through each of the display functions.</p> <p>To reset the display press and hold the display button until the screen fills. Release the button and the display functions will now be reset to zero.</p>
<p><b>SPEED</b></p>	<p><b>SPEED:</b> Displays your workout speed. This is the top number on the monitor display and will show throughout your workout.</p>
<p><b>SCAN</b></p>	<p><b>SCAN:</b> This function allows the computer to scan or rotate through each workout data readout automatically (RPM, ODO, TIME, CAL, DIST). The scan function is in process when the <b>SCAN</b> icon is illuminated and flashing on the side of the lower number on the display.</p>
<p><b>RPM</b></p>	<p><b>REVOLUTIONS PER MINUTE:</b> This function tracks the number of revolutions the pedals make per minute.</p>
<p><b>ODO</b></p>	<p><b>ODOMETER:</b> This function displays the total distance you have traveled on the cycle. This function is a cumulative total of distance travelled and will maintain the amount when you reset all other functions.</p>
<p><b>TIME</b></p>	<p><b>TIME:</b> This function displays the duration of your workout.</p>
<p><b>CAL</b></p>	<p><b>CALORIES:</b> This function displays the calories you have burned during your workout. The calorie count is based on an average weight therefore the results are only an estimate. This result should not be used for medical purposes.</p>
<p><b>DIST</b></p>	<p><b>DISTANCE:</b> This function displays the distance you have traveled on during your workout.</p>

# MOVING THE sitNcycle AND RESISTANCE ADJUSTMENT

## Transporting

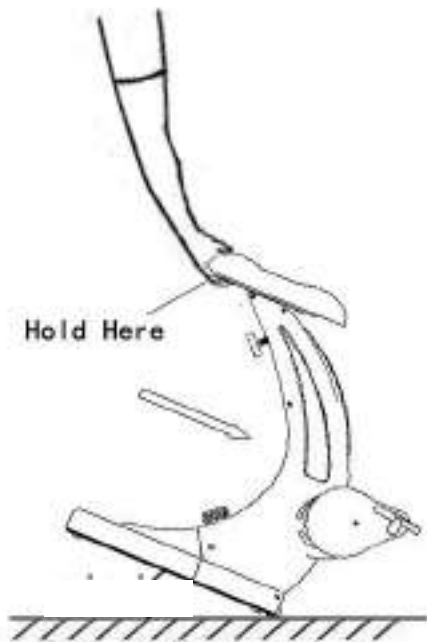

**Verify that the seat is locked in place and cannot be removed. Verify the seat adjustment knob is fully tightened.**

1. Lower the seat to the lowest height setting. Prior to moving the unit verify that the seat is locked in place and the seat adjustment knob is fully tightened.
2. There is a transportation handle under the back of the seat.
3. Hold the transportation handle and tilt the unit forward until the wheels are resting on the floor. (about 15 to 20 degrees).
4. Roll the unit forward to the desired location.
5. Once the unit is in place, verify that all 4 stabilizing feet are firmly in contact with the floor. This equipment must be placed on a level and stable hard flooring or carpet.

**Failure to follow the instructions above may cause the seat to become disengaged from the unit frame during transportation.**

## Adjusting the Resistance

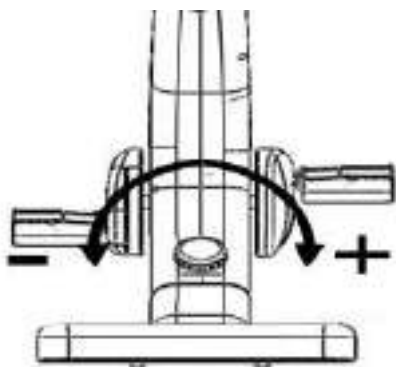

1. There are numbers on the resistance dial ranging from 1 through 8. Number 1 is the least amount of resistance offered and number 8 is the maximum amount offered.
2. To increase the resistance, turn the dial clockwise.
3. To decrease the resistance, turn the dial counter-clockwise.

## sitNcycle USAGE

Resistance	It is recommended that the resistance level is selected prior to using the machine. Start by setting the resistance to the easiest level before trying a more challenging resistance level.
How to get on and off the machine	Do not have your feet on the pedals when getting on or off the machine. Your feet should be firmly on the ground. It is recommended getting on or off the machine from the front. <i>Make sure that adequate space is available for access to and passage around the equipment; keep at least a distance of 1 meter from any obstruction object while using the machine.</i>
Use	This product is designed to be used as a cardiovascular exercise. After being properly seated and balanced on the machine begin pedaling in a circular forward motion. Be certain to sit up straight and keep proper posture to target the body's core muscles

# WORKOUT RECOMMENDATIONS

Prior to each workout, perform a few warm-up exercises in order to prevent excessive straining of your muscles and to reduce the risk of injury. After each workout, perform some cool-down exercises as well in order to gradually relax your muscles.

## MUSCLE CHART

### Targeted muscle groups:

The exercise routine that is performed on this product will develop primarily lower body muscle groups. These muscle groups are shown in gray color on the chart below.

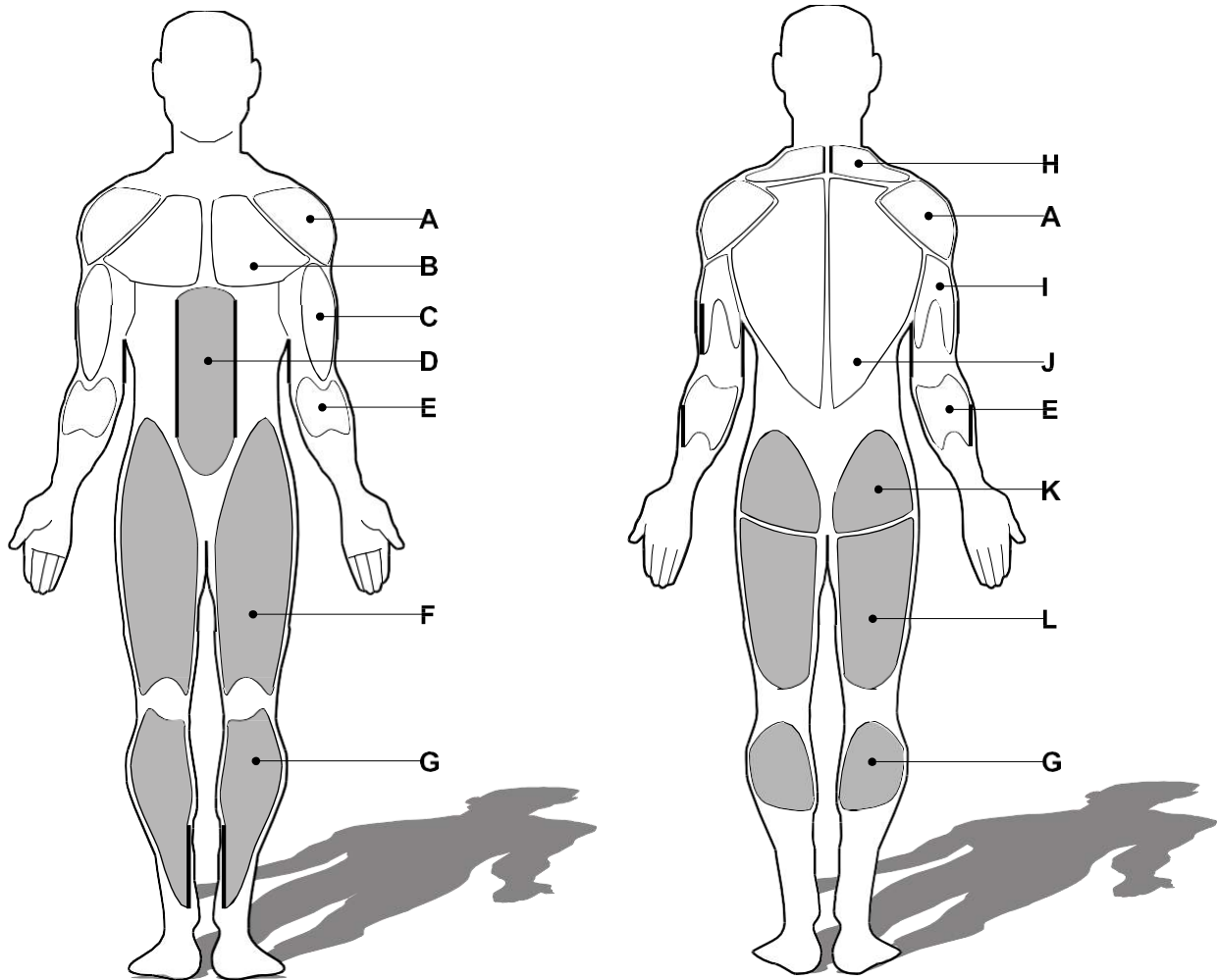

### Muscle Groups

A	Shoulder muscles		Calf muscles	G
B	Pectoral muscles		Trapezius muscles	H
C	Bicep muscles		Tricep muscles	I
D	Abdominal muscles		Back muscles	J
E	Forearm muscles		Gluteal muscles	K
F	Quadricep muscles		Hamstring muscles	L

## STRETCHING ROUTINE

### Warm up and cool down:

A successful exercise program consists of a warm-up, aerobic exercise, and a cool-down. Do the entire program at least two and preferably three times a week, resting for a day between workouts. After several months, you can increase your workouts to four or five times per week.

Warming up is an important part of your workout, and should begin every session. It prepares your body for more strenuous exercise by heating up and stretching out your muscles, increasing your circulation and pulse rate, and delivering more oxygen to your muscles. At the end of your workout, repeat these exercises to reduce sore muscle problems. We suggest the warm-up and cool-down exercises on the following pages:

### Toe Touch:

Slowly bend forward from your waist, letting your back and shoulders relax as you stretch toward your toes. Reach down as far as you can and hold for 15 counts.



### Shoulder Lift:

Lift your right shoulder up toward your ear for one count. Then lift your left shoulder up for one count as you lower your right shoulder.

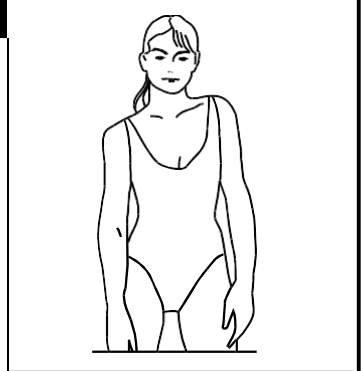

### Inner Thigh Stretch:

Sit with the soles of your feet together with your knees pointing outward. Pull your feet as close into your groin as possible. Gently push your knees towards the floor. Hold for 15 counts.



### Hamstring Stretch:

Sit with your right leg extended. Rest the sole of your left foot against your right inner thigh. Stretch toward your toe as far as possible. Hold for 15 counts. Relax and then repeat with left leg extended.

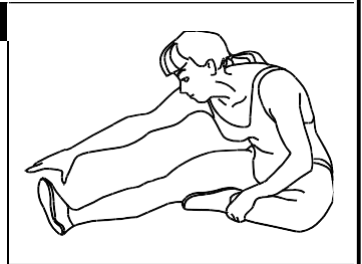

### Side Stretch:

Open your arms to the side and continue lifting them until they are over your head. Reach your right arm as far upward toward the ceiling as you can for one count. Feel the stretch up your right side. Repeat this action with your left arm.

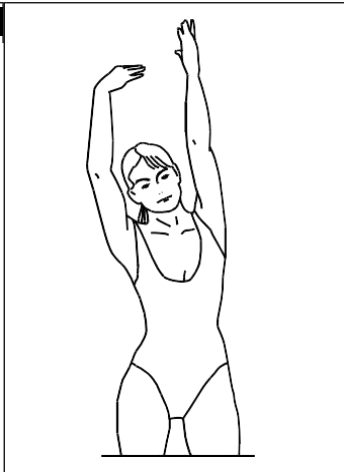

### Calf-Achilles Stretch:

Lean against a wall with your left leg in front of the right and your arms forward. Keep your right leg straight and the left foot on the floor; then bend the left leg and lean forward by moving your hips toward the wall. Hold, and then repeat on the other side for 15 counts.

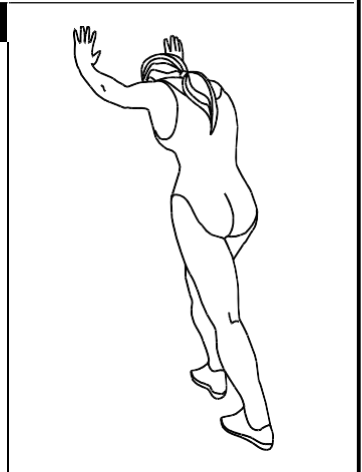

### Head Roll:

Rotate your head to the right for one count, feeling the stretch up the left side of your neck. Next, rotate your head back for one count, stretching your chin to the ceiling and letting your mouth open. Rotate your head to the left for one count, and finally, drop your head to your chest for one count.

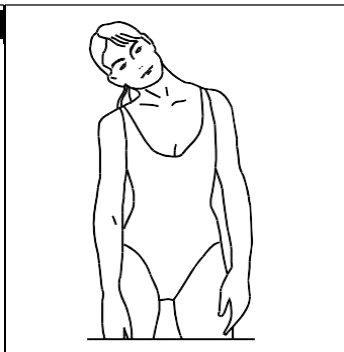

# Exploded Diagram

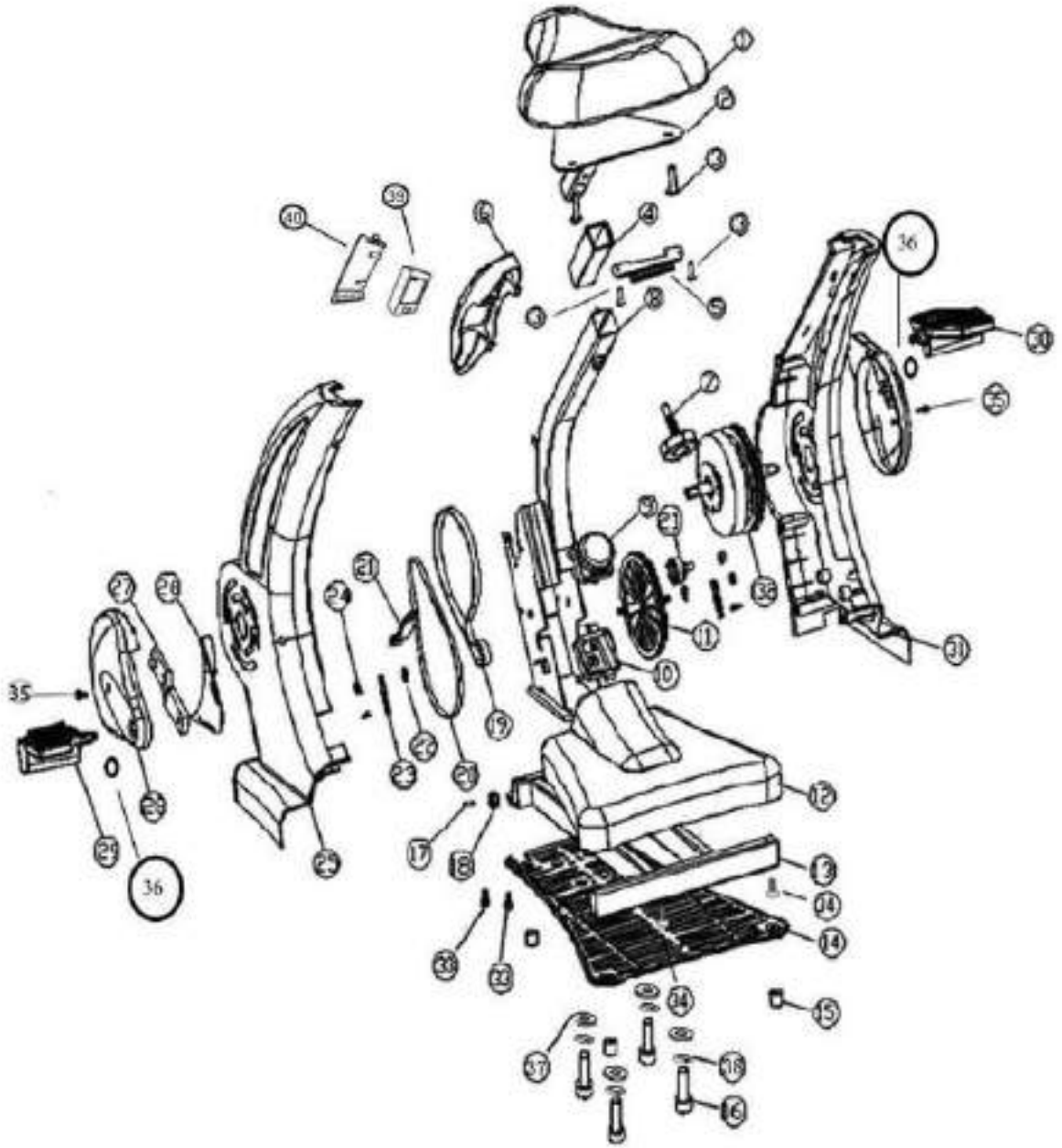

# PART LIST

NO.	Item Name	Q'TY
SNC2JY-1	Seat	1
SNC2JY-2	Seat Post	1
SNC2JY-3	M5x15mm Allen head bolts	5
SNC2JY-4	Seat Tube Sleeve	1
SNC2JY-5	Handle	1
SNC2JY-6	Front Decorative Cover	1
SNC2JY-7	Seat Adjustment Knob	1
SNC2JY-8	Main Frame	1
SNC2JY-9	Resistance Adjustment Knob	1
SNC2JY-10	Resistance Adjustment Knob Cable Box	1
SNC2JY-11	Crank Pulley	1
SNC2JY-12	Base Frame Cover Upper	1
SNC2JY-13	Base Frame	1
SNC2JY-14	Base Frame Cover Lower	1
SNC2JY-15	Foot Pad (screw4×M8×9)	4
SNC2JY-16	M10x13mm Allen Head Bolts	4
SNC2JY-17	Wheel Pin	2
SNC2JY-18	Wheel	2
SNC2JY-19	Belt 1	1
SNC2JY-20	Belt 2	1
SNC2JY-21	Magnetic Array	1
SNC2JY-22	Shim	2
SNC2JY-23	Bar	2
SNC2JY-24	Nut(M8)	4
SNC2JY-25	Left Main Frame Cover	1
SNC2JY-26	Inside Crank Cover	2
SNC2JY-27L	Crank Arm	1
SNC2JY-27R	Crank Arm	1
SNC2JY-28	Outside Crank Cover	2
SNC2JY-29	Left Pedal	1
SNC2JY-30	Right Pedal	1
SNC2JY-31	Right Main Frame Cover	1
SNC2JY-32	Flywheel	1
SNC2JY-33	Pan Head Screw18mm	6
SNC2JY-34	Truss Head Screw 15mm	4
SNC2JY-35	ScrewM5x30mm	2
SNC2JY-36	Φ 13mm Spring Washer	2
SNC2JY-37	Φ10mm Spring Washer	4
SNC2JY-38	Φ10mm Flat Washer	4
SNC2JY-39	Display Monitor	1
SNC2JY-40	Display Monitor Door	1



## LIMITED HOME USE WARRANTY – SCN Products LLC Warranty

**Warranty Coverage:** SCN Products LLC warrants to the original owner that each new product will be free from defects in workmanship and material, under normal use and conditions.

**Period of Coverage:** The Warranty on this product runs from the date of original purchase using the following schedule:

Model Name	Plastics, Upholstery and Wear and Tear Parts	Frame and Mechanical Parts
sitNcycle	90 days	1 year

SCN Products LLC reserves the right to inspect damaged parts for misuse. Your Original Receipt is proof of purchase and should be kept with the product manual. You may be required to show proof of purchase prior to warranty fulfillment.

**Remedy Provided by SCN Products LLC:** SCN Products LLC will provide a replacement part free of charge if a defect is found during the Warranty period. SCN Products LLC may at its discretion choose to provide any of the stipulated parts or repair options. In the event that a part is determined to be in need of replacement, upon receipt of the defective part by SCN Products LLC, SCN Products LLC may send out the part by UPS Ground or another such carrier directly to the customer's home at the customer's expense.

Any redemption may be by repair or replacement of the affected part(s) and/or product at the sole discretion of SCN Products LLC, by personnel approved by SCN Products LLC.

Parts repaired or replaced pursuant to this Warranty shall be warranted for the unexpired portion of the Warranty applying to the original product. Any technical advice furnished before or after delivery in regard to the use or application of SCN Products LLC products is furnished without charge and on the basis that it represents SCN Products LLC's best judgment under the circumstances, however, the advice is used solely at the customer's discretion.

**Procedure for Obtaining Your Remedy Under This Warranty:** To help the technician assist you over the phone, please have the following information ready:

- Model name or number from the cover of the manual;
- Serial number located on the frame of the unit; and
- The part description and the order number.

**Limitations on Warranty:** This Warranty does not cover any problems, damage or failure that are caused by accident, improper assembly, failure to observe cautionary labels on the product, failure to operate the product correctly, power grid failures or spikes from your local electricity provider, abuse or freight damage. SCN Products LLC does not warrant against any damage or defects that may result from repair or alterations made to the product by an unauthorized repair facility. In order for this warranty to be valid, all SCN Products LLC exercise equipment must be stored and used in a fully finished and livable room within the residence (not including an indoor swimming pool room).

This Warranty shall terminate if you sell or otherwise transfer this product. This Warranty does not apply to any product shipped or handled outside of the United States or Canada. This Warranty does not apply if the product is used as a rental product or in commercial use. Consequential and incidental damages are not recoverable under this Warranty. (Some states do not allow the exclusion or limitation of incidental or consequential damages, so the above limitation or exclusion may not apply to you.)

THIS WARRANTY IS EXPRESSLY IN LIEU OF ALL OTHER WARRANTIES. ALL IMPLIED WARRANTIES, INCLUDING WARRANTIES OF MERCHANTABILITY OR FITNESS FOR ANY PARTICULAR PURPOSE ARE LIMITED IN DURATION TO ONE (1) YEAR FROM THE EFFECTIVE DATE OF THIS WARRANTY. SCN PRODUCTS LLC IS NOT LIABLE FOR CONSEQUENTIAL OR INCIDENTAL DAMAGES RESULTING FROM ANY DEFECT IN PARTS NOR FOR ANY BREACH OF EXPRESS OR IMPLIED WARRANTIES. SCN PRODUCTS LLC'S SOLE LIABILITY UNDER THIS WARRANTY IS LIMITED TO THE TERMS DESCRIBED IN THIS FORM. THIS WARRANTY GIVES YOU SPECIFIC LEGAL RIGHTS, AND YOU MAY ALSO HAVE OTHER RIGHTS WHICH VARY FROM STATE TO STATE.

FORM WS-1 (rev. 02/2016)



Customer Service 1-855-663-5643